

OSHKOSH[®]

Straight J Plow

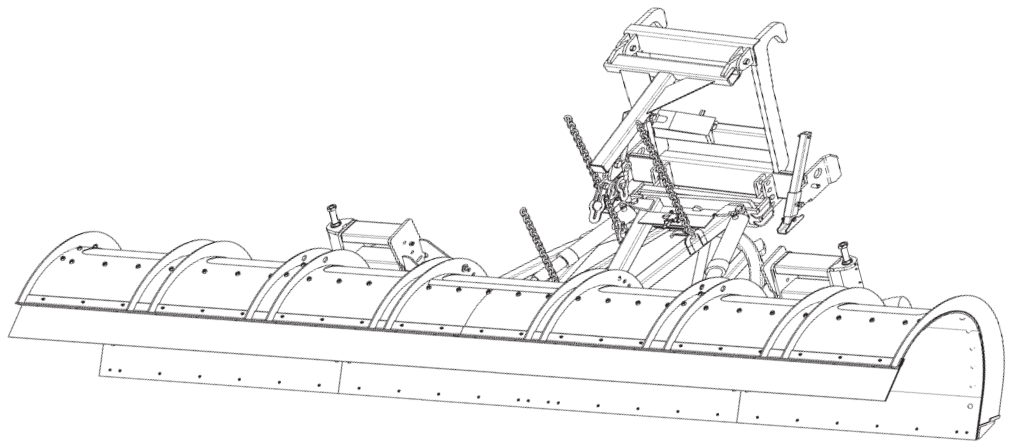

	OTC 14' Straight J	OTC 16' Straight J	OTC 18' Straight J	OTC 20' Straight J	OTC 22' Straight J	OTC 24' Straight J
Moldboard height	50"					
Discharge height	50"					
Plow Throat depth from vertical to deepest point in	11-1/2"					
Moldboard thickness & type of steel	3/8" VHMW Polyethylene, 3/16" steel backing plate					
Type, size and number of vertical reinforcement ribs	3/8" steel plate varying cross section from 3" to 7-3/4", 10 Ribs	12 Ribs	12 Ribs	12 Ribs	14 Ribs	14 Ribs
Cutting edge attack angles	65, 75, 85 Degrees					
Number of hook up points from moldboard to frame	4 pins with 6 cushions					
Size and type of reinforced snow flap	12" x 3/8" thick rubber belting					
Carbide cutting Edge (AASHTO punched) size	3/4" x 6", 3' and 4' pieces					
Distance beyond vertical that snow deflectors integral with moldboard extends	16-1/2"					
Size of adjustable casters	10" x 6" wheels: 20.5" x 8" Load Range E Tires					
Approximate weight of plow (less hitch and hydraulics)	3,900 pounds	4,200	4,450	4,700	4,930	5,180
Cushion Mounting System	Six (6) rubber isolator biscuits between frame and moldboard. Trip systems optional.					
Painting system with type of paint	Phosphate prep with epoxy primer and urethane topcoat					
Warranty provided	One year					

All plows are available with a choice of hitch: Oshkosh hook, DIN/flat face, pin type, Hustings style 40", or Oshkosh Hands Free quick hitch.

All plows are available with a choice of cutting edge: standard steel, carbide, polyurethane, rubber or rubber with carbide insert.

Ask your Oshkosh representative about underbody blades, available in both 2-function and 3-function models.



OSHKOSH®

Flared Plow

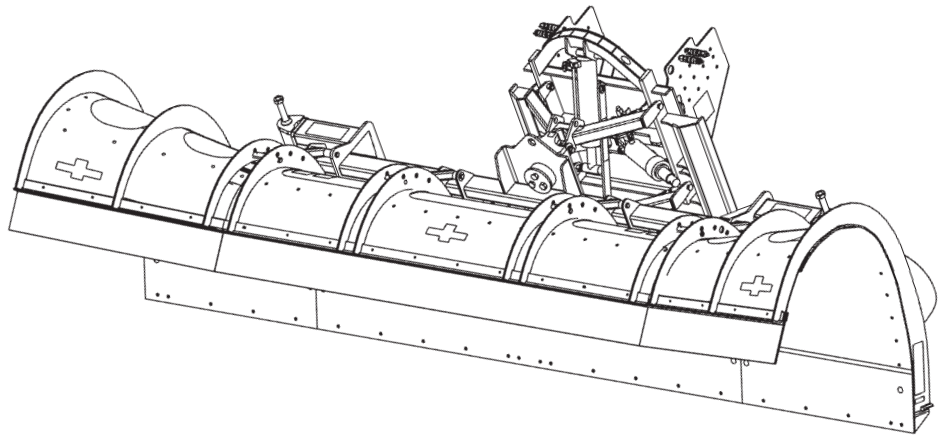

	OTC 14' Flared	OTC 16' Flared	OTC 18' Flared	OTC 20' Flared	OTC 22' Flared	OTC 24' Flared
Moldboard height	50"					
Discharge height	64"	67"	67"	70"	73"	76"
Plow Throat depth from vertical to deepest point in	11-1/2"					
Moldboard thickness & type of steel	3/8" VHMW Polyethylene 3/16" steel backing plate					
Type, size and number of vertical reinforcement ribs	3/8" steel plate varying cross section from 3" to 7-3/4", 10 Ribs	12 Ribs	12 Ribs	12 Ribs	14 Ribs	14 Ribs
Cutting edge attack angles	65, 75, 85 Degrees					
Number of hook up points from moldboard to frame	4 pins with 6 cushions					
Size and type of reinforced snow flap	12" x 3/8" thick rubber belting					
Carbide cutting Edge (AASHTO punched) size	3/4" x 6", 3' and 4' pieces					
Distance beyond vertical that snow deflectors integral with moldboard extends	16-1/2"					
Size of adjustable casters	10" x 6" wheels: 20.5" x 8" Load Range E Tires					
Approximate weight of plow (less hitch and hydraulics)	3,950 pounds	4,250 pounds	4,550 pounds	4,850 pounds	5,180 pounds	5,480 pounds
Cushion Mounting System	Six (6) rubber isolator biscuits between frame and moldboard. Trip systems optional.					
Painting system with type of paint	Phosphate prep with epoxy primer and urethane topcoat					
Warranty provided	One year					

All plows are available with a choice of hitch: Oshkosh hook, DIN/flat face, pin type, Hustings style 40", or Oshkosh Hands Free quick hitch.

All plows are available with a choice of cutting edge: standard steel, carbide, polyurethane, rubber or rubber with carbide insert.

Ask your Oshkosh representative about underbody blades, available in both 2-function and 3-function models.

